

REVISIONS				
LTR	DESCRIPTION	REV BY	APPROVED	DATE
A	INITIAL RELEASE	BJH	KET	10/19/00
B	SEE ECO N54400B	BJH	KET	4/12/01
C	SEE ECO N54400C	BJH	KET	2/5/02

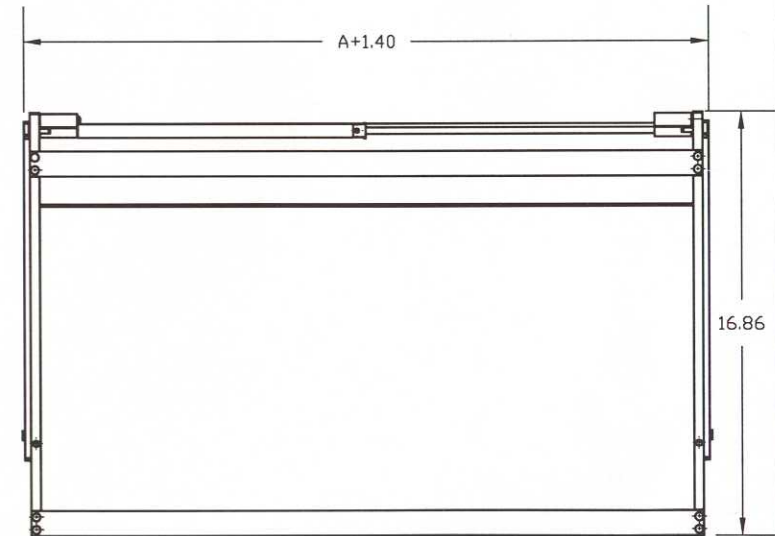
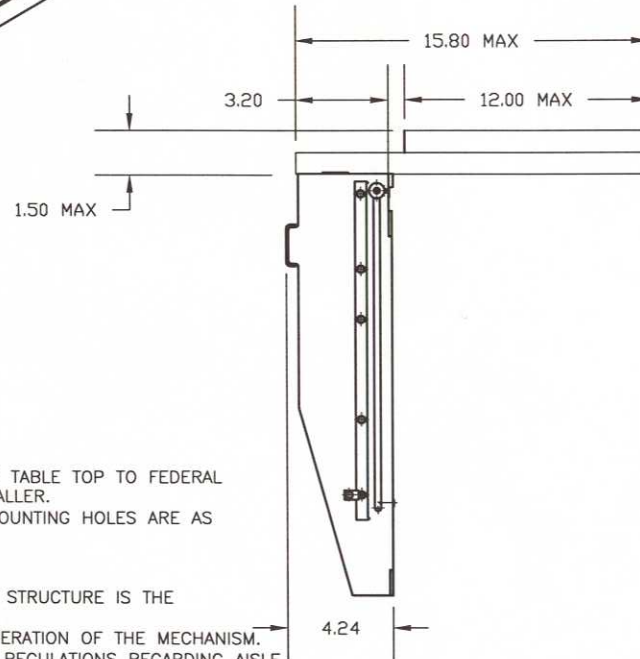
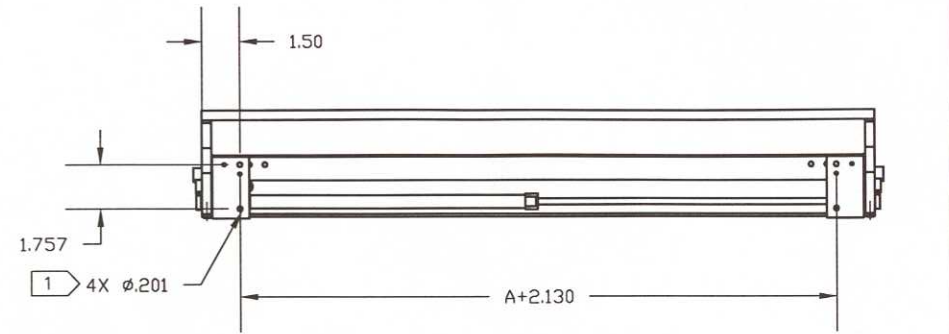
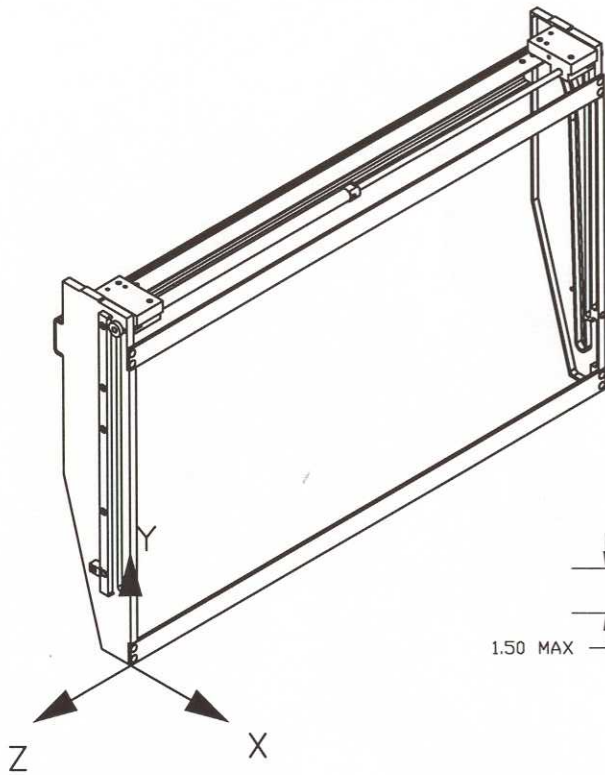

A = DASH NUMBER (TABLE TOP WIDTH)

NOTES:

TABLE TOP INFORMATION

A) THE COMPLIANCE OF THE INSTALLATION OF THE TABLE TOP TO FEDERAL REGULATIONS IS THE RESPONSIBILITY OF THE INSTALLER.

B) THE SIZE AND LOCATION OF THE TABLE TOP MOUNTING HOLES ARE AS INDICATED.

AIRCRAFT ATTACHMENT INFORMATION

A) STRUCTURAL SUBSTANTIATION OF THE AIRCRAFT STRUCTURE IS THE RESPONSIBILITY OF THE INSTALLER.

B) FASTENERS MUST NOT INTERFERE WITH THE OPERATION OF THE MECHANISM.

C) COMPLIANCE TO APPLICABLE FEDERAL AVIATION REGULATIONS REGARDING AISLE CLEARANCE REQUIREMENTS IS THE RESPONSIBILITY OF THE INSTALLER.

MECHANICAL INFORMATION

A) WEIGHT OF THE MECHANISM - 4.04 LBS FOR A -26 TABLE (± 0.065 LB PER INCH)

B) THE LOCATION OF THE CENTER OF GRAVITY IN THE STOWED POSITION IS AT $X = -1.44$, $Y = 7.88$. THE CENTER OF GRAVITY IN THE DEPLOYED POSITION IS LOCATED AT $X = -1.54$, $Y = 11.66$. Z IS APPROX AT THE GEOMETRIC CENTER.

C) THE MECHANISM CAN SUPPORT AN ULTIMATE LOAD OF 150 LBS APPLIED 10.85 INCHES FROM THE INBOARD FACE OF THE SIDEPLATES AND CENTERED ON THE A DIMENSION. SEE STRESS REPORT R22165. CONVERT ULTIMATE LOAD TO AN ALLOWABLE TABLE TOP WEIGHT WITH THE FOLLOWING FORMULA:

(WEIGHT OF ITEMS + WEIGHT OF TABLE TOP) X ULTIMATE LOAD FACTOR MUST BE LESS THAN OR EQUAL TO 150 LBS.

E) SEE OPERATION MANUAL M22165 FOR ADDITIONAL INFORMATION ON MECHANISM OPERATION AND MAINTENANCE.

1

<i>Released</i>	DRAWN BJH 10/11/00	 Austin, Texas		
	FINISH: NONE			
INSPECTION CLASS A	MATERIAL: NONE	TITLE 54400 INSTALLATION DRAWING		
UNLESS OTHERWISE SPECIFIED TOLERANCES: DECIMAL XX ± .01 XXX ± .005	ANGULAR ± 1°	SIZE A	DWG NO. N54400	REV. C
DIMENSIONS ARE IN INCHES ALL MACHINED SURFACES DO NOT SCALE DRAWING REMOVE ALL BURRS & SHARP EDGES .010-.015		The data, concepts or designs contained herein are the exclusive property of Enlite, Inc. or contain the proprietary rights of others and shall not be used, disclosed, copied, digitized or reproduced without the written consent of Enlite, Inc.		SCALE NONE
		CAD FILE 54400-XX-F-C	SHEET 1	OF 1