

REVISIONS				
LTR	DESCRIPTION	REV BY	APPROVED	DATE
A	INITIAL RELEASE	BJH	KOT	2/2/02

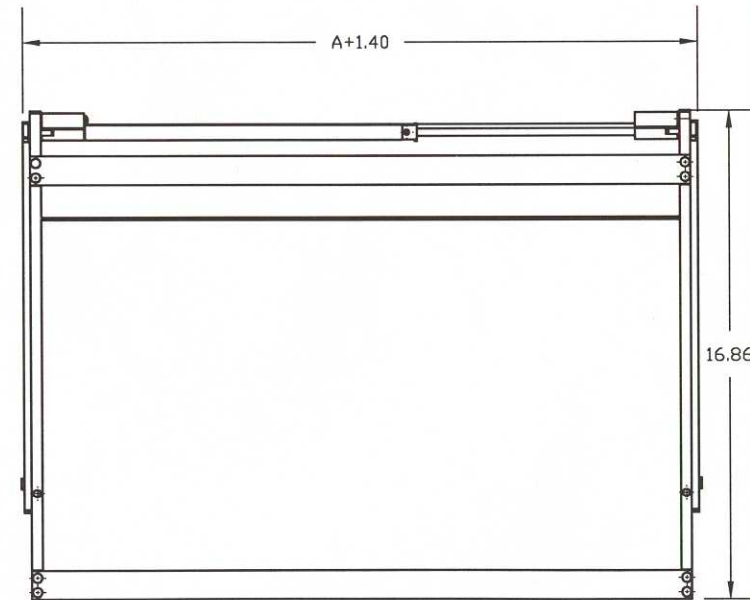
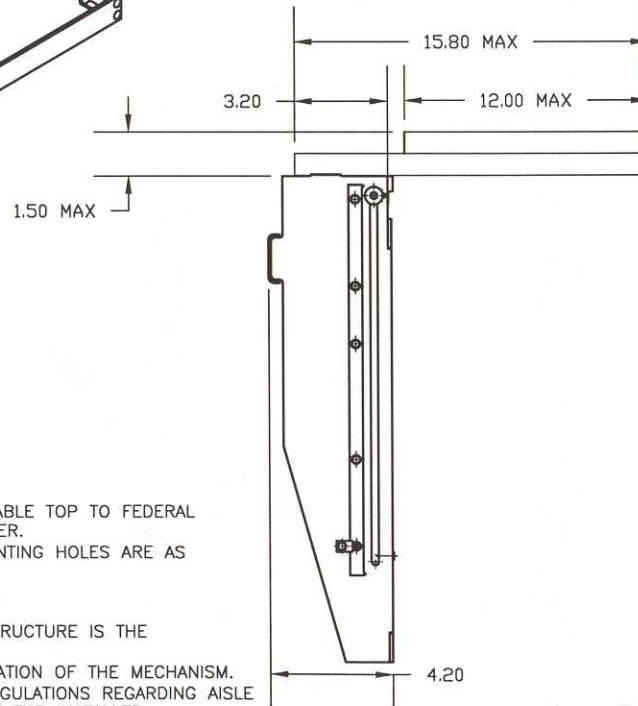
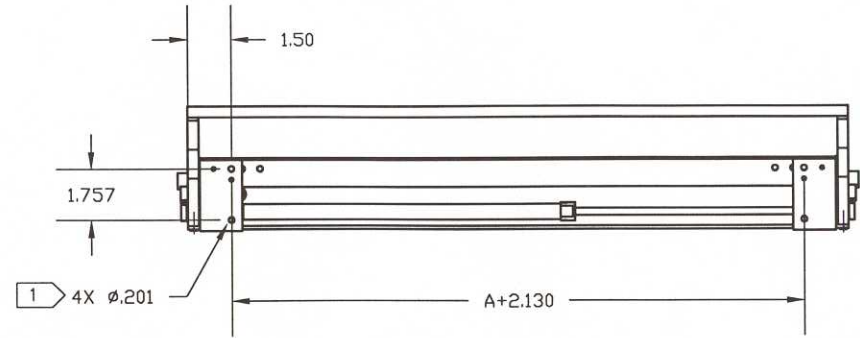
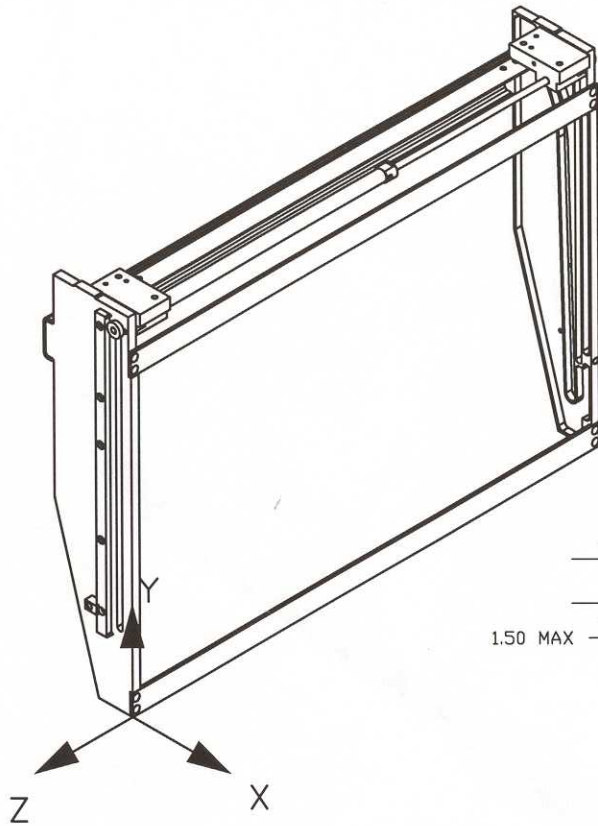

NOTES:

TABLE TOP INFORMATION

A) THE COMPLIANCE OF THE INSTALLATION OF THE TABLE TOP TO FEDERAL REGULATIONS IS THE RESPONSIBILITY OF THE INSTALLER.

B) THE SIZE AND LOCATION OF THE TABLE TOP MOUNTING HOLES ARE AS INDICATED.

AIRCRAFT ATTACHMENT INFORMATION

A) STRUCTURAL SUBSTANTIATION OF THE AIRCRAFT STRUCTURE IS THE RESPONSIBILITY OF THE INSTALLER.

B) FASTENERS MUST NOT INTERFERE WITH THE OPERATION OF THE MECHANISM.

C) COMPLIANCE TO APPLICABLE FEDERAL AVIATION REGULATIONS REGARDING AISLE CLEARANCE REQUIREMENTS IS THE RESPONSIBILITY OF THE INSTALLER.

MECHANICAL INFORMATION

A) WEIGHT OF THE MECHANISM - 3.78 LBS FOR A -22 TABLE ( $\pm .06$  LB PER INCH)

B) THE LOCATION OF THE CENTER OF GRAVITY IN THE STOWED POSITION IS AT  $X=-1.44$ ,  $Y=7.88$ . THE CENTER OF GRAVITY IN THE DEPLOYED POSITION IS LOCATED AT  $X=-1.54$ ,  $Y=10.91$ . Z IS APPROX AT THE GEOMETRIC CENTER.

C) THE MECHANISM CAN SUPPORT AN ULTIMATE LOAD OF 150 LBS APPLIED 10.85 INCHES FROM THE INBOARD FACE OF THE SIDEPLATES AND CENTERED ON THE A DIMENSION. SEE STRESS REPORT R22165. CONVERT ULTIMATE LOAD TO AN ALLOWABLE TABLE TOP WEIGHT WITH THE FOLLOWING FORMULA:

(WEIGHT OF ITEMS + WEIGHT OF TABLE TOP) X ULTIMATE LOAD FACTOR MUST BE LESS THAN OR EQUAL TO 150 LBS.

E) SEE OPERATION MANUAL M22165 FOR ADDITIONAL INFORMATION ON MECHANISM OPERATION AND MAINTENANCE.

A= DASH NUMBER (TABLE TOP WIDTH)

<p style="font-size: 2em; color: blue;">Released</p>	DRAWN BJH1/28/01	 Austin, Texas		
	FINISH: NONE			
INSPECTION CLASS A	MATERIAL: NONE	TITLE 54550 INSTALLATION DRAWING		
<small>UNLESS OTHERWISE SPECIFIED TOLERANCES:</small> DECIMAL .XX $\pm .01$ .XXX $\pm .005$ ANGULAR $\pm 1^\circ$	<small>DIMENSIONS ARE IN INCHES</small> <small>ALL MACHINED SURFACES <math>\phi</math></small> <small>DO NOT SCALE DRAWING</small> <small>REMOVE ALL BURRS &amp; SHARP EDGES .010-.015</small>	<small>The data, concepts or designs contained herein are the exclusive property of Enlite, Inc. or contain the proprietary rights of others and shall not be used, disclosed, copied, duplicated or reproduced without the written consent of Enlite, Inc.</small>	SIZE A DWG NO. N54550 SCALE NONE	REV. A SHEET 1 OF 1