

NOTES:

1) TABLE TOP INFORMATION

- A) THE COMPLIANCE OF THE INSTALLATION OF THE TABLE TOP TO FEDERAL AVIATION REGULATIONS IS THE RESPONSIBILITY OF THE INSTALLER.
- B) THE SIZE AND LOCATION OF THE TABLE TOP MOUNTING HOLES ARE AS INDICATED.

2) AIRCRAFT ATTACHMENT INFORMATION

- A) STRUCTURAL SUBSTANTIATION OF THE AIRCRAFT STRUCTURE IS THE RESPONSIBILITY OF THE INSTALLER.
- B) FASTENERS MUST NOT INTERFERE WITH THE OPERATION OF THE MECHANISM. FASTENERS ARE GENERALLY INSTALLED IN THE SIDEPLATES.
- C) COMPLIANCE TO APPLICABLE FEDERAL AVIATION REGULATIONS REGARDING AISLE CLEARANCE REQUIREMENTS ARE THE RESPONSIBILITY OF THE INSTALLER.

3) MECHANICAL INFORMATION

- A) WEIGHT OF MECHANISM: 12.00 LBS FOR 27" TABLE, ±.09 LBS PER INCH. THE CENTER OF GRAVITY WHEN DEPLOYED IS X= 1.25, Y= 13.69 WHEN STOWED IS X=1.40, Y= 7.36 WITH Z BEING THE GEOMETRIC CENTER OF THE TABLE.

THE MECHANISM CAN SUPPORT 236 LBS ULTIMATE APPLIED 13 INCHES FROM

- B) THE INBOARD EDGE OF THE MECHANISM. SEE STRESS REPORT "R22250". CONVERT ULTIMATE LOAD TO AN ALLOWABLE TABLE TOP WEIGHT AND ITEMS WITH
- C) THE FOLLOWING FORMULA:

(WEIGHT OF ITEMS + WEIGHT OF TABLE TOP) X ULTIMATE LOAD FACTOR ≤ 236
SEE OPERATION MANUAL "M22500" FOR ADDITIONAL INFORMATION ON MECHANISM OPERATION AND MAINTENANCE.

4) SCREW ADJUSTMENTS

THE ARM ADJUSTING SCREWS HAVE BEEN SET TO MINIMIZE TABLE TOP DEFLECTION. IF, AFTER INSTALLATION, A GAP APPEARS BETWEEN THE ARM ADJUSTING SCREWS AND THE STRAP WHEN DEPLOYED, THEY MUST BE READJUSTED (SEE MAINTENANCE MANUAL M22500)
DO NOT USE THE ARM ADJUSTING SCREWS TO LEVEL THE TABLE TOP. LEVELING OF THE TABLE TOP MUST BE DONE USING THE LEVELING SET SCREWS.

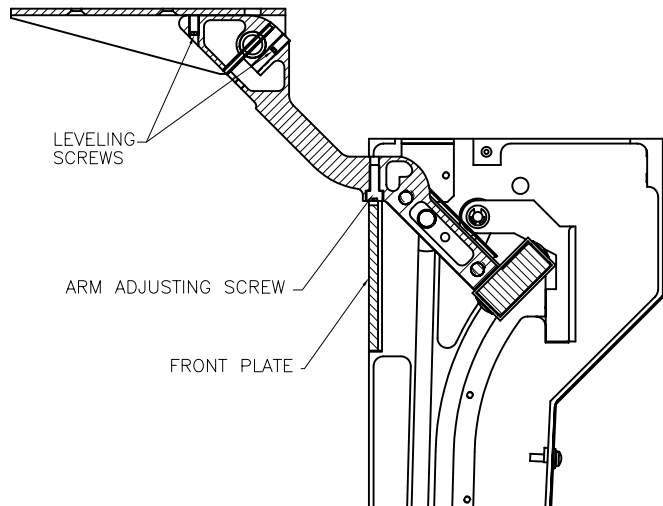

ARM AND LEVELING SCREWS

REVISIONS				
LTR	DESCRIPTION	REV BY	APPROVED	DATE
A	INITIAL RELEASE	THH	VHT	3/14/05
B	SEE ECO 55150ZB	DG	VHT	04/20/06

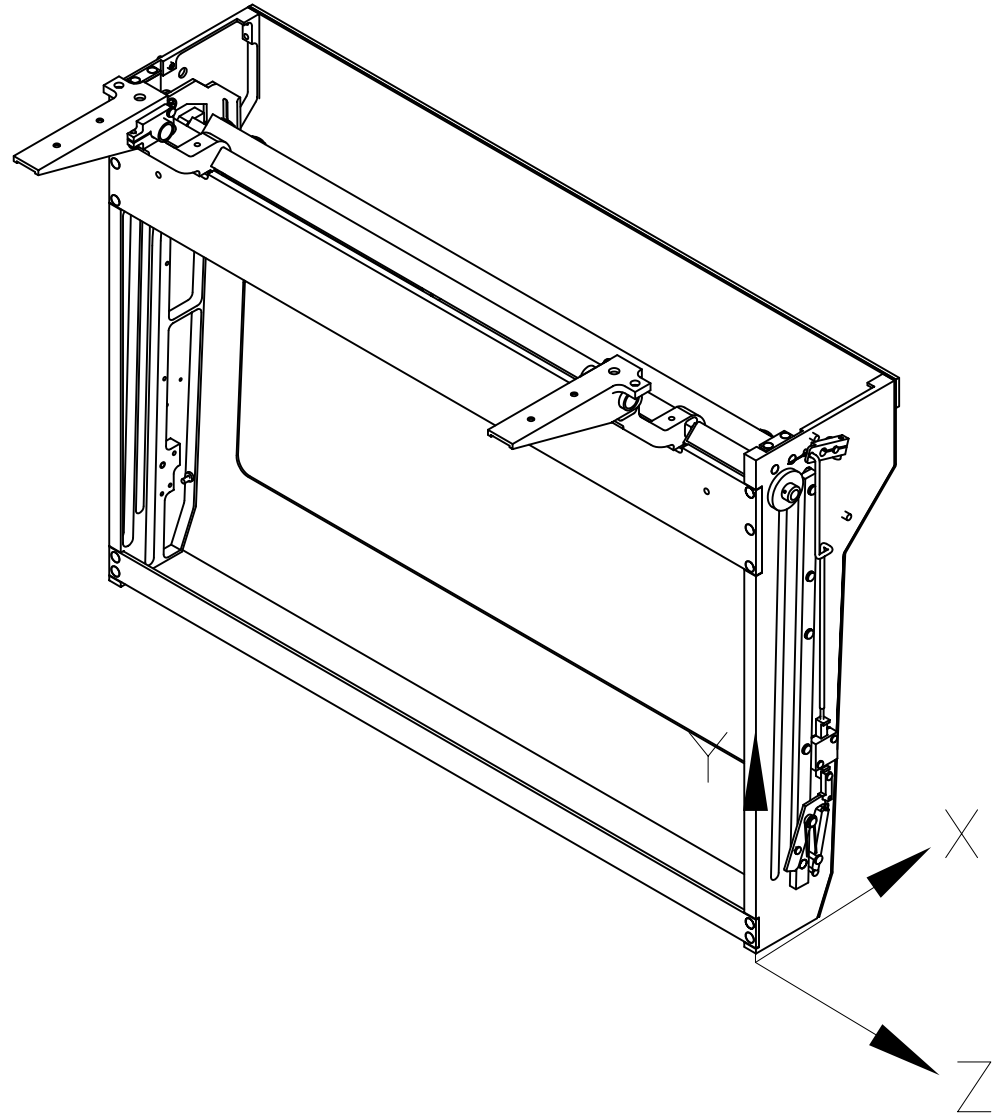

INSPECTION CLASS	DRAWN	 Austin, Texas		
	THH 3/05/05			
UNLESS OTHERWISE SPECIFIED TOLERANCES: DECIMAL .XX ± .01 ANGULAR ± 1° .XXX ± .005 DIMENSIONS ARE IN INCHES ALL MACHINED SURFACES $\frac{63}{\sqrt{}}$ DO NOT SCALE DRAWING REMOVE ALL BURRS & SHARP EDGES .010-.015	FINISH:	TITLE SIDE WALL TABLE INSTALLATION		
	N/A			
MATERIAL: N/A <i>The data, concepts or designs contained herein are the exclusive property of Enflite, Inc. or contain the proprietary rights of others and shall not be used, disclosed, copied, duplicated or reproduced without the written consent of Enflite, Inc.</i>	SIZE	DWG NO.	REV.	
	A	N55150Z	B	
	SCALE NONE	CAD FILE	SHEET	OF
		55150Z-XX-B-B	1 OF 2	

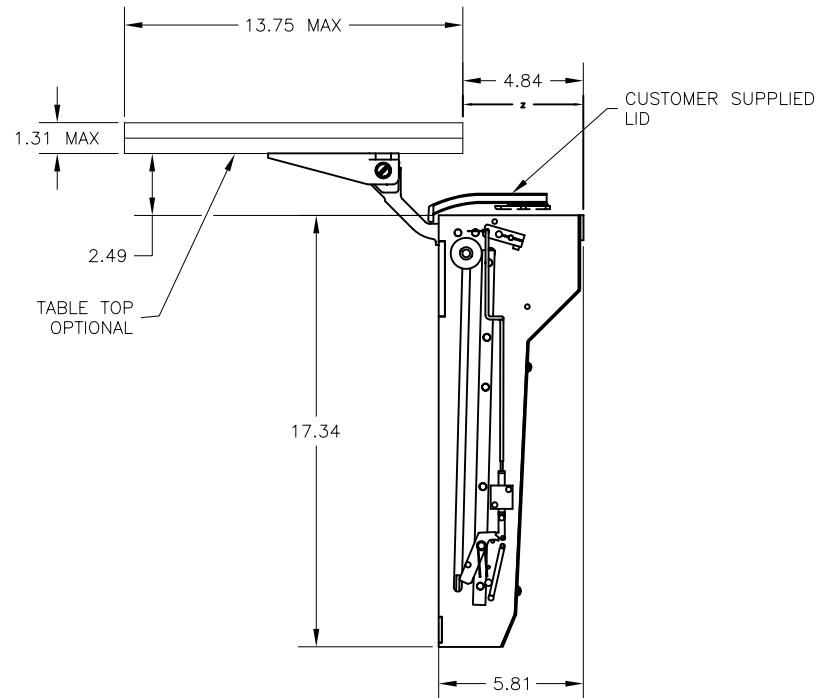
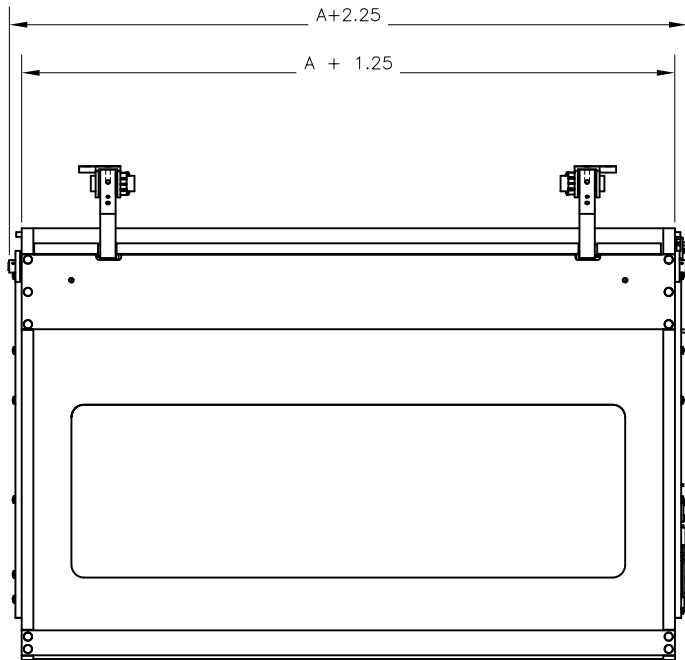
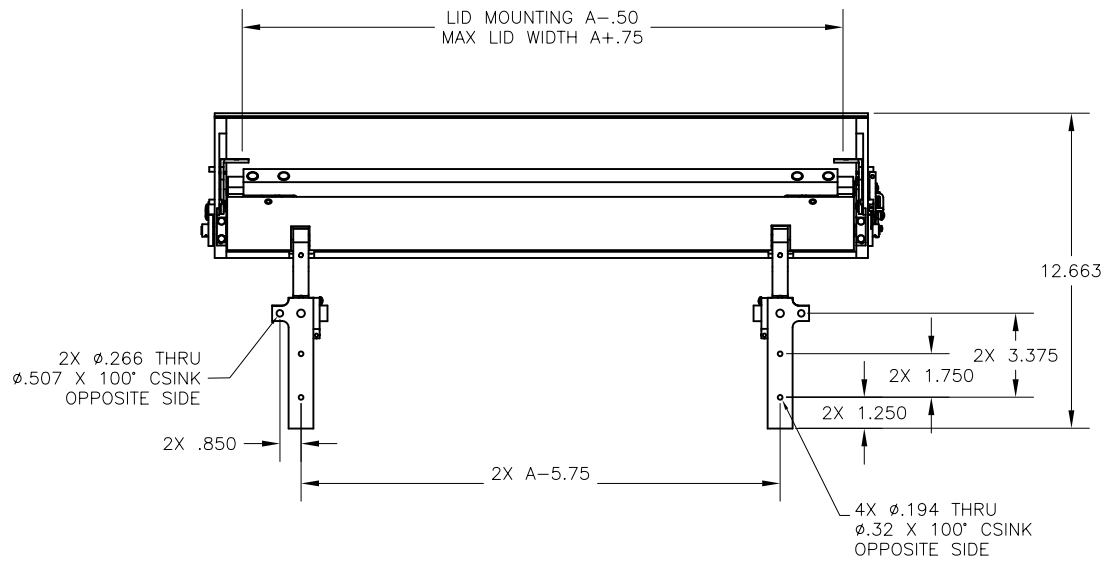

A = DASH NUMBER (WIDTH OF TABLE)

SIZE A	DWG NO. N55150Z	REV. B
SCALE NONE	CAD FILE 55150-XX-B-B	SHEET 2 OF 2