

2

1

NOTES:

- 1) REFER TO THE TOP LEVEL "ERP" BILL OF MATERIAL FOR ACTUAL TOP PLATE, BOTTOM PLATE, AND THE TABLE LEG PART NUMBERS. SUPPLY A COPY OF THE "ERP" BILL OF MATERIALS AND DRAWINGS OF REQUIRED TOP PLATE, BOTTOM PLATE, AND TABLE LEGS WITH THIS DOCUMENT. USE THE DRAWINGS TO DEFINE ACTUAL TABLE DIMENSIONS FOR INSTALLATION.
- 2) ATTACHMENT OF P/N 70220-XX (PEDESTAL) TO THE TABLE TOP.
 - A. THE WEIGHT OF THE TABLE TOP MUST NOT EXCEED 24 LBS.
 - B. THE CENTER OF GRAVITY OF THE TABLE TOP MUST BE WITHIN 5 INCH OF THE CENTERLINE OF THE PEDESTAL.
 - C. THE TABLE TOP MUST BE FASTENED TO THE PEDESTAL WITH FOUR BOLTS IN THE HATCHED AREA SHOWN IN THE TOP VIEW. ADDITIONAL FASTNERS OUTSIDE THE HATCHED AREA MAY IMPROVE RIGIDITY.
 - D. THE COMPLIANCE OF THE TABLE TOP TO FEDERAL AVIATION REGULATIONS IS THE RESPONSIBILITY OF THE INSTALLER.
- 3) ATTACHMENT OF P/N 70220-XX (PEDESTAL) TO AIRCRAFT STRUCTURE.
 - A. THE PEDESTAL TABLE TOP ASSEMBLY MUST BE FASTENED TO THE AIRCRAFT STRUCTURE WITH (MINIMUM) FOUR BOLTS OR SCREWS IN HATCHED AREA SHOWN IN SECTION A-A. ADDITIONAL FASTNERS OUTSIDE THE HATCHED AREA MAY IMPROVE RIGIDITY.
 - B. THE ABILITY OF THE AIRCRAFT STRUCTURE TO RESIST THE LOADS OF THE PEDESTAL TABLE TOP ASSEMBLY UNDER THE DESIGN LOAD FACTORS (SEE NOTE 4) IS THE RESPONSIBILITY OF THE INSTALLER.
 - C. COMPLIANCE TO APPLICABLE FEDERAL AVIATION REGULATIONS REGARDING AISLE CLEARANCE REQUIREMENTS IS THE RESPONSIBILITY OF THE INSTALLER.
- 3) DESIGN LOAD FACTORS
 - A. THE FOLLOWING LOAD FACTORS WERE USED IN CONSIDERING THE STRUCTURAL INTEGRITY OF THE PEDESTAL:

FORWARD:	9.00G
AFT:	1.50G
LATERAL:	3.00G
UP:	6.50G
DOWN:	9.60G

THESE LOAD FACTORS MEET OR EXCEED THE REQUIREMENTS OF FAR PART 25.561.

REVISIONS				
REV	DESCRIPTION	REV BY	APPROVED	DATE
A	INITIAL RELEASE	RAB	KET	9/20/02
B	SEE ECO N7220B	THH	KPW	6/11/04
C	SEE ECO N70220C	MAR		DO NOT USE

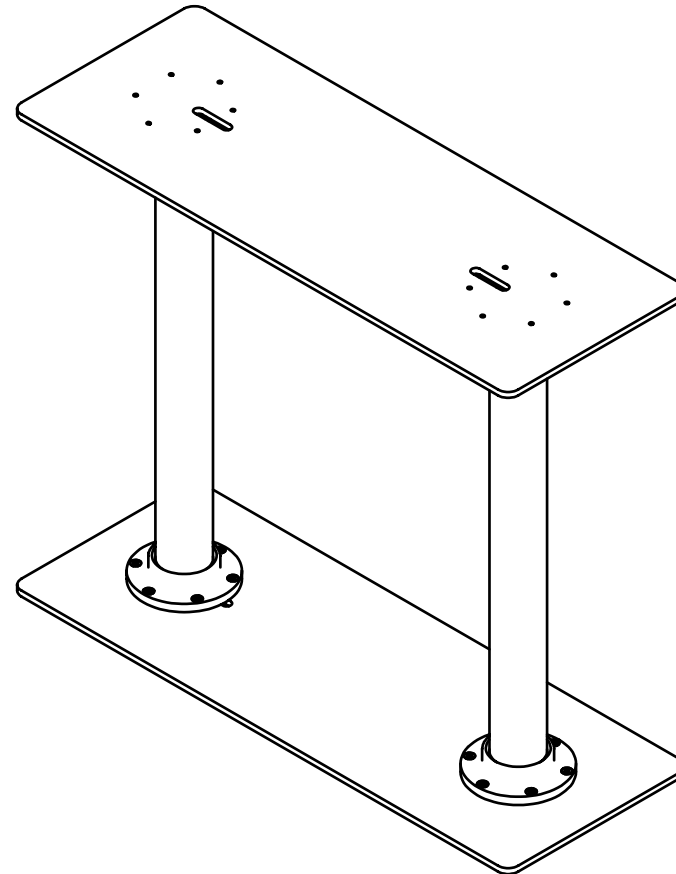

INSPECTION CLASS C		DRAWN MAR 8/23/2005		 Georgetown, Texas	
UNLESS OTHERWISE SPECIFIED TOLERANCES:		FINISH: NONE			
DECIMAL	ANGULAR	MATERIAL: SEE NOTES		PEDESTAL TABLE, FIXED HEIGHT 2.0" DIA LEG	
.XX ± .04	± 1°				
.XXX ± .04		SIZE A		DWG NO. N70220	REV. C
DIMENSIONS ARE IN INCHES		SCALE NONE		CAD FILE N70220.idw	SHEET 1 OF 2
ALL MACHINED SURFACES √		<small>The data, concepts or designs contained herein are the exclusive property of Enflite, Inc. or contain the proprietary rights of others and shall not be used, disclosed, copied, duplicated or reproduced without the written consent of Enflite, Inc.</small>			
DO NOT SCALE DRAWING					
REMOVE ALL BURRS & SHARP EDGES .010-.015					

2

1

2



1

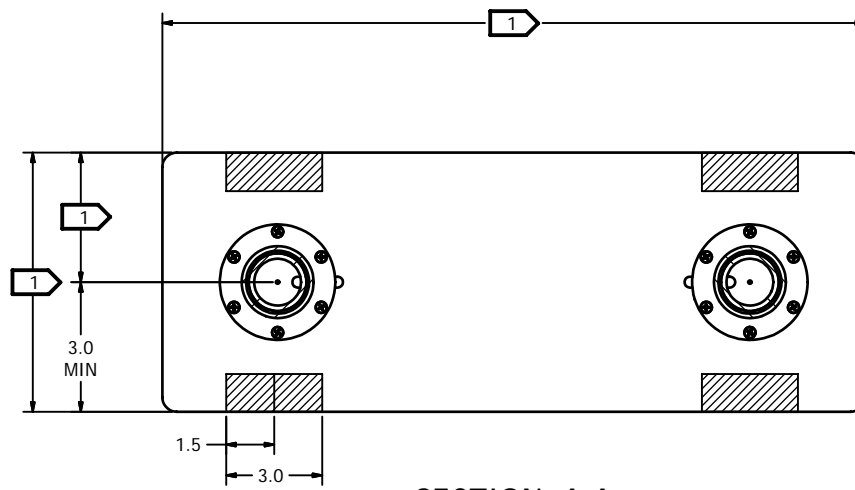
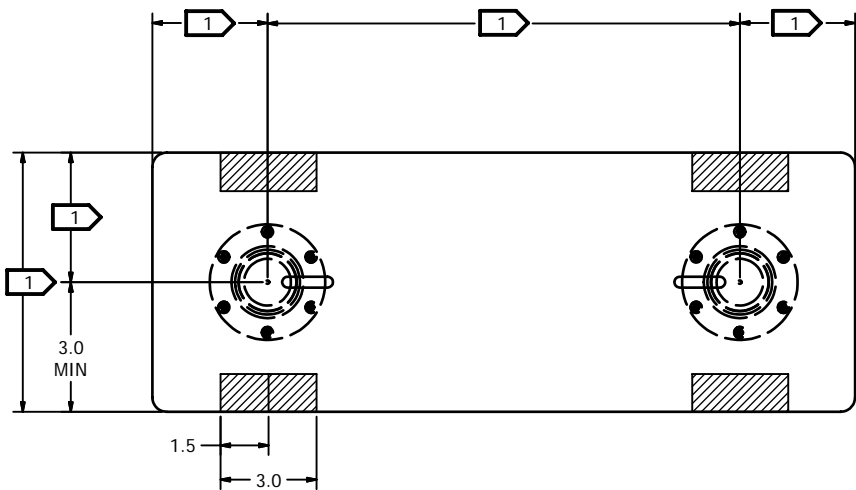

SECTION A-A

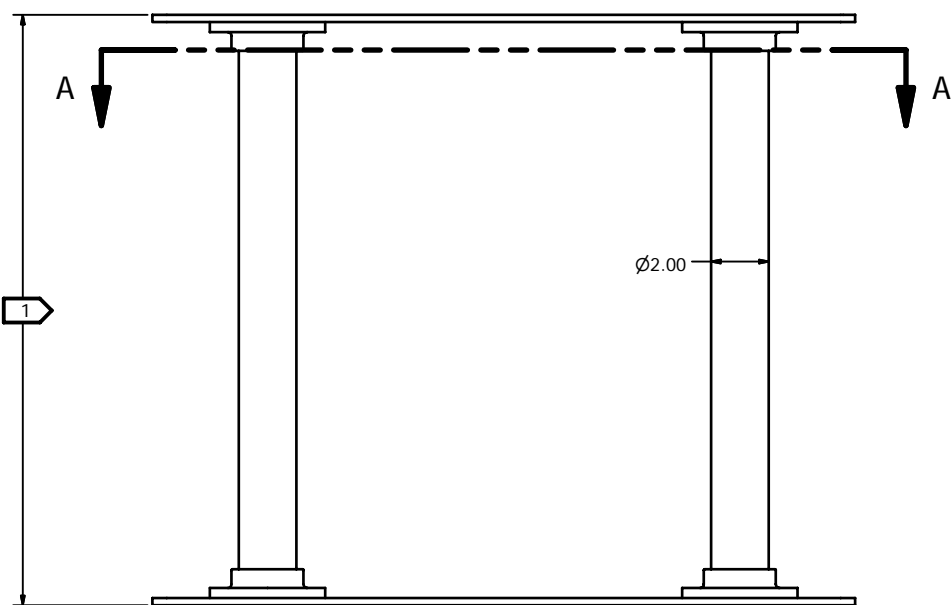

A

A

2



1

SIZE A	DWG NO. N70220	REV. C
SCALE NONE	CAD FILE N70220.idw	SHEET 2 OF 2