

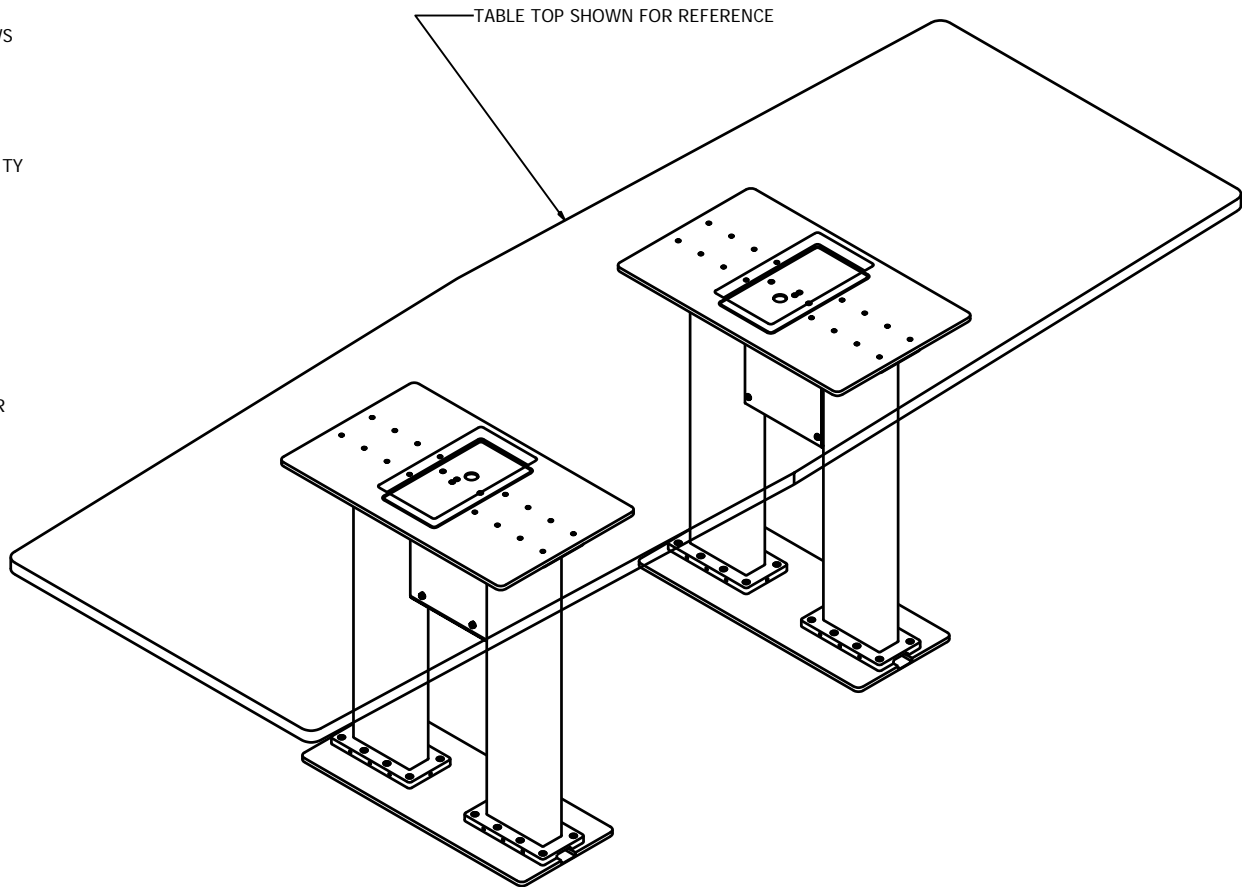

NOTES:

1. ATTACHMENT OF TABLE TOP TO THE PEDESTAL.
 - A. THE WEIGHT OF THE TABLE TOP MUST NOT EXCEED 75 LBS.
 - B. THE TABLE TOP SHALL BE FASTENED TO THE PEDESTAL WITH AT LEAST EIGHT AN3 BOLTS (OR EQUIV). ADDITIONAL BOLTS MAY IMPROVE RIGIDITY.
 - C. THE COMPLIANCE OF THE TABLE TOP TO FEDERAL AVIATION REGULATIONS IS THE RESPONSIBILITY OF THE INSTALLER.

2. ATTACHMENT OF THE PEDESTAL ASSEMBLY TO AIRCRAFT STRUCTURE.
 - A. THE PEDESTAL TABLE ASSEMBLY SHALL BE FASTENED TO THE AIRCRAFT STRUCTURE WITH A MINIMUM OF EIGHT NAS517-3 SCREWS (OR EQUIV).
 - B. THE ABILITY OF THE AIRCRAFT STRUCTURE TO RESIST THE LOADS OF THE PEDESTAL TABLE ASSEMBLY UNDER THE DESIGN LOAD FACTORS (SEE NOTE 3) IS THE RESPONSIBILITY OF THE INSTALLER.
 - C. COMPLIANCE TO APPLICABLE FEDERAL AVIATION REGULATIONS REGARDING AISLE CLEARANCE REQUIREMENTS IS THE RESPONSIBILITY OF THE INSTALLER.

3. DESIGN LOAD FACTORS.
 - A. THE FOLLOWING LOAD FACTORS WERE USED IN CONSIDERING THE STRUCTURAL INTEGRITY OF THE PEDESTAL:
 - FORWARD: 9.00 G
 - AFT: 9.00 G
 - LATERAL: 9.00 G
 - UP: 6.50 G
 - DOWN: 9.60 G
 THESE LOAD FACTORS MEET OR EXCEED THE REQUIREMENTS OF FAR PART 25.561 AND BOEING ABUSE LOADS.
 - B. SEE STRESS REPORT R70460-1.



INSPECTION CLASS C		DRAWN: EPW	DATE: 6/19/2007	 Georgetown, Texas
UNLESS OTHERWISE SPECIFIED		FINISH: NA		
1) ALL SURFACES PER EPS-121-01-D 2) REMOVE ALL BURRS & SHARP EDGES .010-.015 3) DIMENSIONS ARE IN INCHES 4) DO NOT SCALE DRAWING 5) TOLERANCES: DECIMAL ANGULAR XX ± .04 ± 1° XXX ± .010		MATERIAL: NA		TITLE
6) ALL MACHINED SURFACES 63/		The data, concepts or designs contained herein are the exclusive property of Enfilite, Inc. or contain the proprietary rights of others and shall not be used, disclosed, copied, duplicated or reproduced without the written consent of Enfilite, Inc.		TABLE, PEDESTAL, FIXED HEIGHT, QUAD
SIZE A	DWG NO. N70460	REV. A	SHEET 1 OF 2	

6 5 4 3 2 1

D

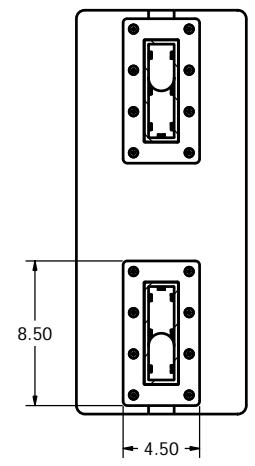
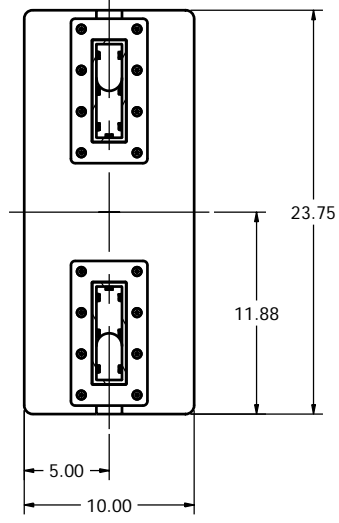
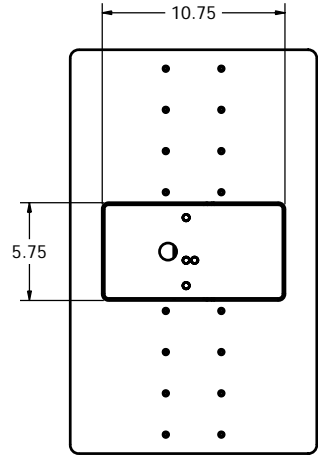
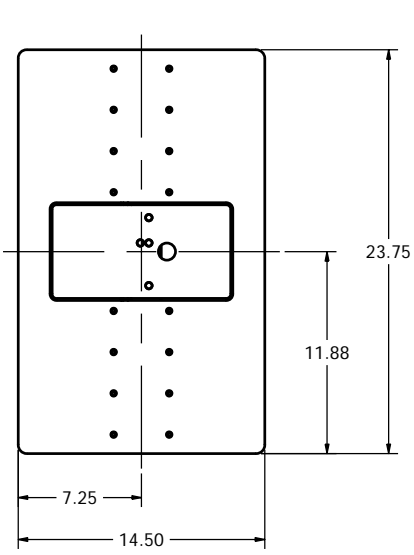

SECTION A-A

C

B

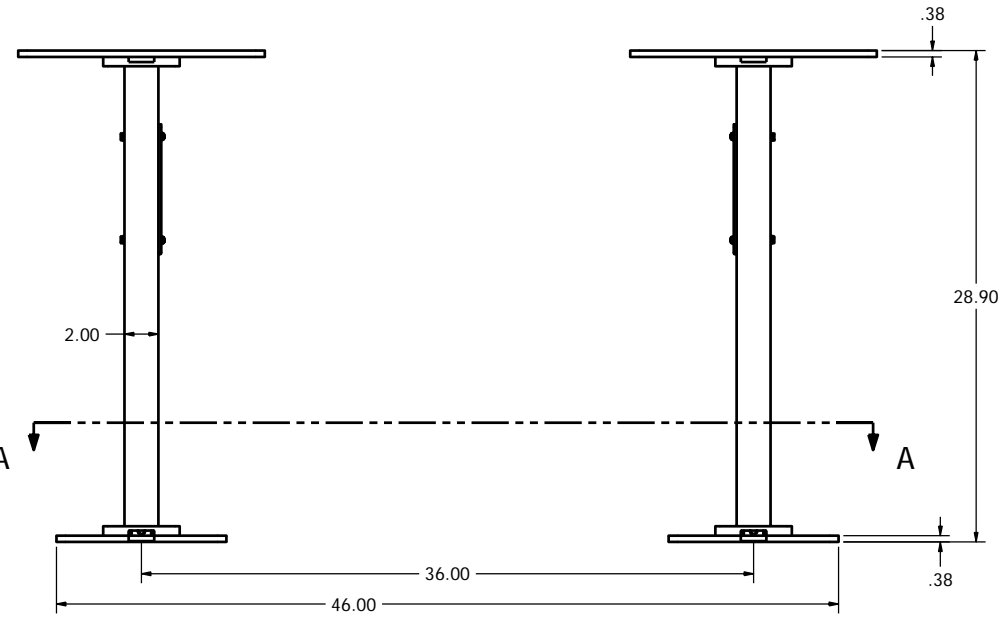

(REFERENCE DRAWING NO. N24601 FOR LIFT SPECS)

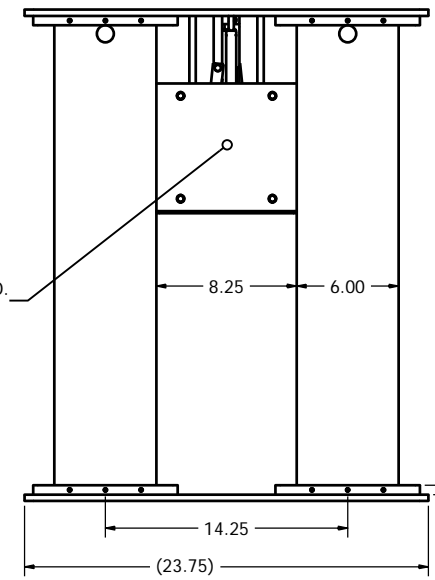

A

6 5 4 3 2 1

SIZE A	DWG NO. N70460	REV. A	SHEET 2 OF 2
-----------	-------------------	-----------	-----------------