

NOTES:

1 REFER TO TOP LEVEL "ERP" BILL OF MATERIALS FOR ACTUAL HEIGHT AND WIDTH DEPENDENT PART NUMBERS THAT ARE REQUIRED. SUPPLY A COPY OF THE "ERP" BILL OF MATERIALS AND THE DRAWINGS OF THE REQUIRED PARTS NEEDED WITH THIS DOCUMENT. USE THE DRAWINGS AND CUSTOMER SPEC SHEET TO DEFINE ACTUAL TABLE DIMENSIONS FOR INSTALLATION.

2 ATTACHMENT OF P/N 72510-XX PEDESTAL ASSEMBLY TO THE TABLE TOP.

- A. THE WEIGHT OF THE TABLE TOP MUST NOT EXCEED 45 LBS.
- B. THE CENTER OF GRAVITY OF THE TABLE TOP MUST BE WITHIN 5 INCHES OF THE CENTERLINE OF THE PEDESTAL.
- C. THE TABLE TOP MUST BE FASTENED TO THE PEDESTAL WITH A MINIMUM OF FOUR AN3 BOLTS (OR EQUIV.) IN THE HATCHED AREA SHOWN IN THE TOP VIEW. ADDITIONAL SCREWS OUTSIDE THE HATCHED ARE MAY IMPROVE RIGIDITY.
- D. THE COMPLIANCE OF THE TABLE TOP TO FEDERAL AVIATION REGULATIONS IS THE RESPONSIBILITY OF THE INSTALLER.

3 ATTACHMENT OF P/N 72510-XX PEDESTAL ASSEMBLY TO THE AIRCRAFT STRUCTURE.

- A. THE PEDESTAL TABLE TOP ASSEMBLY MUST BE FASTENED TO THE AIRCRAFT STRUCTURE WITH A MINIMUM OF FOUR AN3 BOLTS OR MS24694 SCREWS (OR EQUIV.) IN THE HATCHED AREA SHOWN IN SECTION A-A. ADDITIONAL SCREWS OUTSIDE THE HATCHED AREA MAY IMPROVE RIGIDITY.
  - B. THE ABILITY OF THE AIRCRAFT STRUCTURE TO RESIST THE LOADS OF THE PEDESTAL ASSEMBLY UNDER THE DESIGN LOAD FACTORS (SEE NOTE 4) IS THE RESPONSIBILITY OF THE INSTALLER.
  - C. COMPLIANCE TO APPLICABLE FEDERAL AVIATION REGULATIONS REGARDING AISLE CLEARANCE REQUIREMENTS IS THE RESPONSIBILITY OF THE INSTALLER.
4. DESIGN LOAD FACTORS.
- A. THE FOLLOWING LOAD FACTORS WERE USED IN CONSIDERING THE STRUCTURAL INTEGRITY OF THE PEDESTAL:
    - FORWARD: 9.00 G
    - AFT: 3.27 G
    - LATERAL: 3.00 G
    - UP: 6.50 G
    - DOWN: 9.60 G
 THESE LOAD FACTORS MEET OR EXCEED THE REQUIREMENTS OF 14CFR PART 25.561. SEE STRESS REPORT R72510.
  - B. TABLE MUST BE IN THE STOWED POSITION FOR TAXI, TAKE-OFF AND LANDING, AND MUST BE PLACARDED AS SUCH.

REVISIONS				
REV	DESCRIPTION	REV BY	APPROVED	DATE
A	INITIAL RELEASE	RAB	KET	05/28/2002
B	SEE ECO N72510B	MWI	KPE	06/08/2005
C	SEE ECO N72510C	MWI	VHT	09/06/2005
D	SEE ECO N72510D	EPW	DO NOT USE	

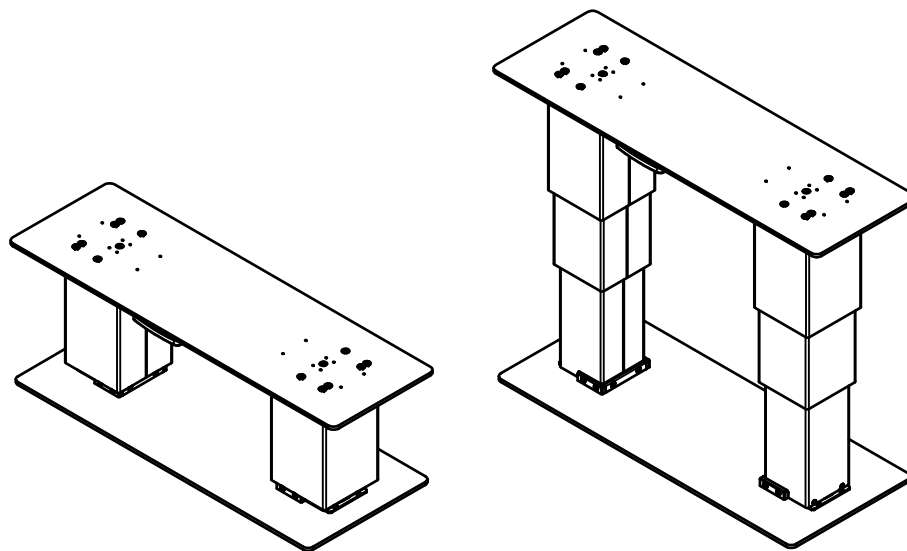

**STOWED**

**DEPLOYED**

INSPECTION CLASS C	DRAWN: RAB	DATE: 5/27/2002	 <p>Georgetown, Texas</p>
UNLESS OTHERWISE SPECIFIED	FINISH: N/A	MATERIAL: N/A	
1) ALL SURFACES PER EPS-121-01-D 2) REMOVE ALL BURRS & SHARP EDGES .010-.015 3) DIMENSIONS ARE IN INCHES 4) DO NOT SCALE DRAWING 5) TOLERANCES: DECIMAL                      ANGULAR .XX ± .04                      ± 1° .XXX ± .010 6) ALL MACHINED SURFACES 63/	The data, concepts or designs contained herein are the exclusive property of Entilite, Inc. or contain the proprietary rights of others and shall not be used, disclosed, copied, duplicated or reproduced without the written consent of Entilite, Inc.		TITLE <b>PEDISTAL TABLE, LO-STOW,                  2-POSITION, MANUAL</b>
SIZE A	DWG NO. N72510	REV. D	SHEET 1 OF 2

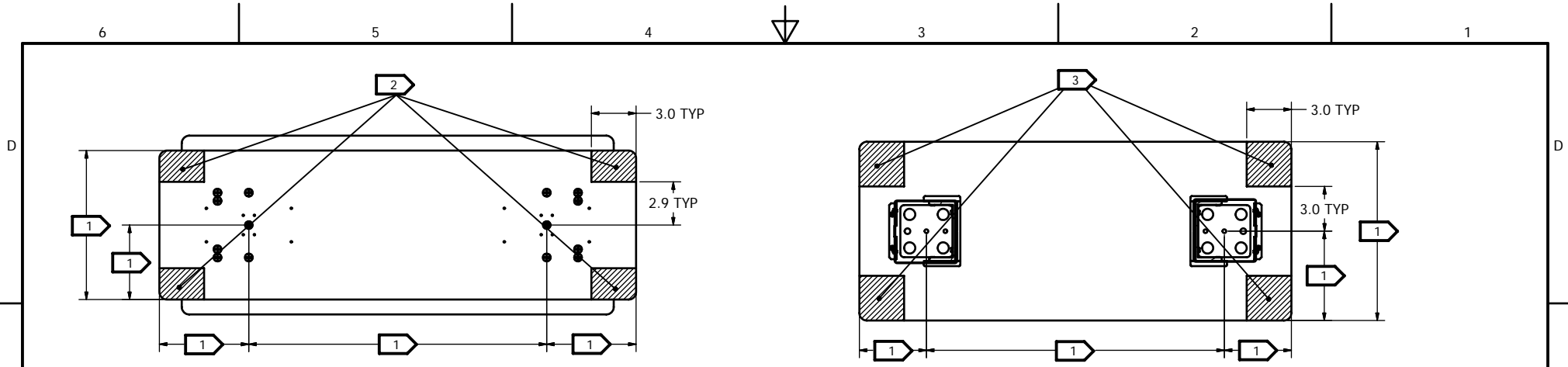

**SECTION A-A**

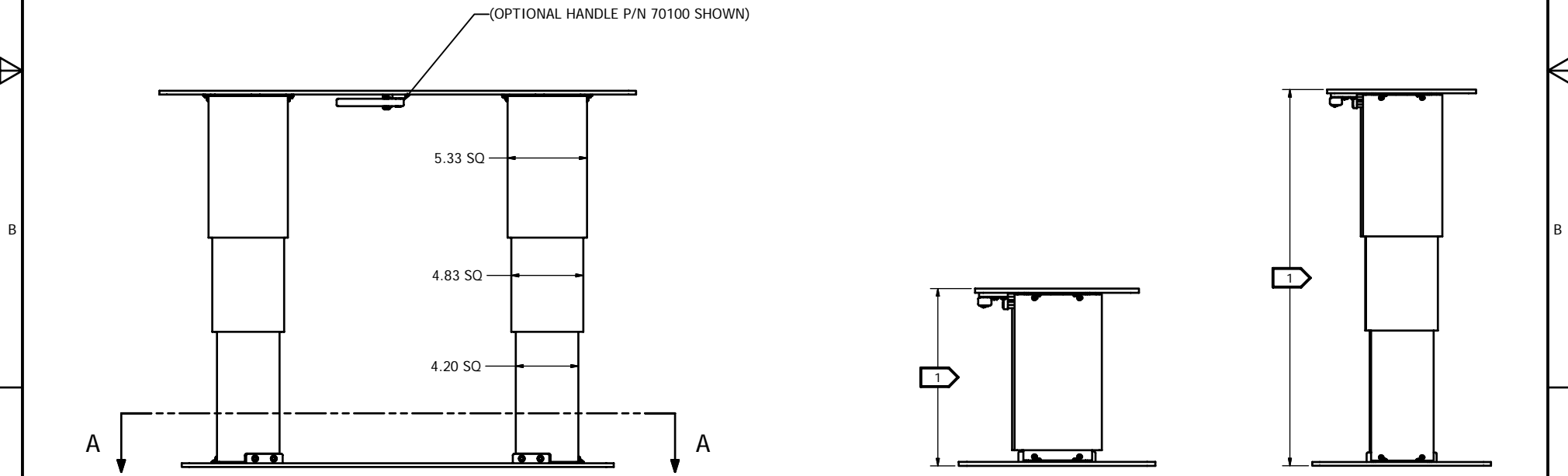

SIZE	DWG NO.	REV.	SHEET
A	N72510	D	2 OF 2